

intermediates. However, the $[S] \gg \text{SiCo}(\text{CO})_4$ system as a catalyst precursor is easily handled and is less sensitive to O_2 than is the solution species $\text{Et}_2\text{SiCo}(\text{CO})_4$. The concept of releasing a catalyst photochemically at a rate controlled by light intensity is one that could be exploited, in principle, in catalytic reactions.

Acknowledgment. We thank the Office of Naval Research for partial support of this research. Support from the Dow Chemical Co. is also gratefully acknowledged. Support for the Fourier transform infrared spectrometer was supplied by the National Institutes of Health, Grant No. GM 27551.

Synthetic Applications of Conjugated Azocarbinols. Radical Chain Hydrophenylation and Hydrocyclohexenylation of Haloethenes[†]

Yau-Min Chang, Ralph Profetto, and John Warkentin*

Contribution from the Department of Chemistry, McMaster University, Hamilton, Ontario, Canada L8S 4M1. Received April 13, 1981

Abstract: 2-(Phenylazo)-2-propanol (**5**) and (phenylazo)diphenylmethanol (**6**) decompose in solution by processes involving phenyl radicals. Similarly, 1-(1-azocyclohexenyl)cyclohexanol (**7**) decomposes in solution to generate the 1-cyclohexenyl radical. Evidence for radical intermediates includes the formation of chlorobenzene and 1-chlorocyclohexene, respectively, from decomposition of **5** (or **6**) and **7** in CCl_4 . Evidence for induced, chain decomposition by radical abstraction of hydroxyl hydrogen, in concert with breaking of at least one C-N bond of the azo function, includes faster decomposition in CCl_4 than in benzene, acceleration of decomposition in CCl_4 by thiophenol, and acceleration of decomposition in benzene by trityl radicals. That decomposition mechanism is supported also by the finding that methyl ethers and acetate esters of the azoalcohols decompose much more slowly than the alcohols themselves. Phenyl radicals from either **5** or **6**, and 1-cyclohexenyl radicals from **7**, can be trapped with some alkenes by addition. Such radical adducts subsequently pick up a hydrogen atom, presumably by abstracting from the hydroxyl group of the azocarbinol in concert with C-N bond breaking. The overall processes, then, are hydrophenylation of alkenes with **5** or **6** and hydro-1-cyclohexenylation of alkenes with **7** by a radical chain mechanism. The processes are of preparative value only in cases of alkene substrates which are neither highly polymerizable nor prone to radical attack on allylic substituents. Several highly halogenated compounds prepared by treatment of haloethenes with **6** or **7** are reported. The reaction between **5** and benzaldehyde, to form acetone and 1-benzoyl-2-phenylhydrazine, was found to be second order overall, first order in **5** and first order in benzaldehyde between 0.4 M and neat benzaldehyde. This result does not appear to be compatible with a mechanism involving decomposition of **5** to acetone and phenyldiazene, with subsequent reaction of the latter with benzaldehyde.

Recently we reported some free radical chemistry of compounds having the α -hydroxyalkyl azo function, $\text{HO}-\text{C}-\text{N}=\text{N}$.¹⁻⁴ Such molecules, **1** and **2**, for example, appear to undergo radical chain, induced decomposition by attack at hydroxyl hydrogen (eq 1 and 2).³ It was possible to make use of such compounds as reagents for radical chain hydroalkylation of alkenes and alkynes (eq 3).⁴

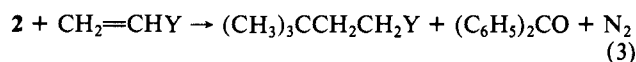
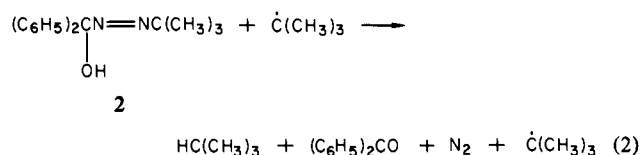
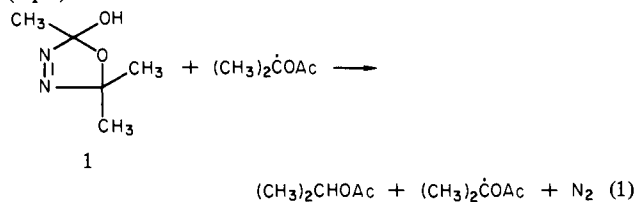

It was interesting to ask whether the chain-transfer ability of the azocarbinol systems would be sufficiently high to permit their use for radical chain hydrophenylation (e.g. with **6**) and hydro-1-alkenylation (e.g., with **7**) of olefinic substrates. We report the

first examples (eq 4 and 5) of those synthetic applications in this paper.

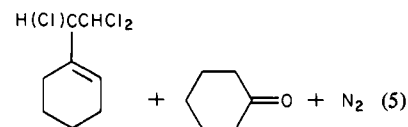
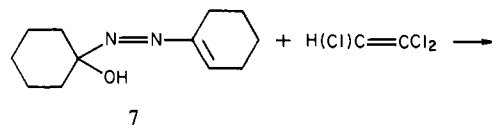
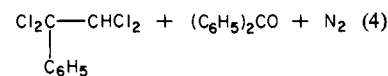
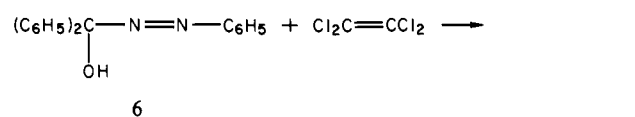

(1) α -Hydroxyalkyl azo compounds were first reported by Schmitz and co-workers^{2a,b} and subsequently by Hünig's group.^{2c-f} They have also been called α -hydroxyalkyldiazenes, semiaminals of diimide, and, by us, azocarbinols. We continue to use the latter, simple but not rigorous, name for the class.

(2) (a) Schmitz, E.; Ohme, R.; Schramm, S. *Angew. Chem., Int. Ed. Engl.* **1963**, *2*, 157. (b) Schmitz, E.; Ohme, R.; Schramm, S. *Justus Liebigs Ann. Chem.* **1967**, *702*, 131. (c) Hünig, S.; Cramer, J. *Angew. Chem., Int. Ed. Engl.* **1968**, *7*, 943. (d) Hünig, S.; Büttner, G. *Ibid.* **1969**, *8*, 451. (e) Büttner, G.; Hünig, S. *Chem. Ber.* **1971**, *104*, 1088. (f) Büttner, G.; Cramer, J.; Geldern, L.; Hünig, S. *Ibid.* **1971**, *104*, 1118.

[†]Dedicated to Dr. George S. Hammond on the occasion of his 60th birthday.

Table I. Reactions of 5 and 6 with Haloethenes

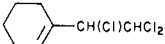
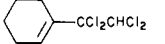
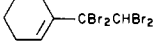
reactants	conditns ^a	product	% yield ^b	spectra ^c
6, ClCH=CCl ₂	ambient, 1 h	C ₆ H ₅ CH(Cl)CHCl ₂ ^d	57, 48	NMR 7.46 (5 H, m), 6.00 (1 H, <i>J</i> = 5.9 Hz), 5.19 (1 H, d, <i>J</i> = 5.9 Hz)
6, Cl ₂ C=CCl ₂	ambient, 48 h	C ₆ H ₅ CCl ₂ CHCl ₂ ^e	53	NMR 7.29 (5 H, m), 6.37 (1 H, s) ^f MS obsd 245.919, 243.920, 241.924; calcd 245.916, 243.919, 241.922
6, Br ₂ C=CBBr ₂	100 °C, 1 h	C ₆ H ₅ CBBr ₂ CHBr ₂ ^g	1.5	NMR 7.43 (1 H, s), 7.33 (5 H, s) MS 426, 424, 422, 420, 418; ratios 1:4:6:4:1
7, ClCH=CCl ₂	reflux, 0.5 h		23	NMR 5.83–6.12 (1 H, m), 5.80 (1 H, d, <i>J</i> = 8.2 Hz), 4.60 (1 H, d, <i>J</i> = 8.2 Hz), 1.2–2.4 (8 H, m) MS 216, 214, 212
7, Cl ₂ C=CCl ₂	35 °C, 48 h		18 ^h	NMR 6.75 (1 H, s), 5.80 (1 H, br t, <i>J</i> = 2 Hz), 1.4–2.3 (8 H, m) MS 250, 248, 246
7, Br ₂ C=CBBr ₂	100 °C, 2 h		22	NMR 7.32 (1 H, s), 6.16 (1 H, m), 1.4–2.3 (8 H, m)

^a See text for general procedure. ^b One yield figure refers to isolated material. If two yields are quoted, the first is the yield of crude product estimated by NMR; the second is the yield of isolated material. ^c NMR data (δ) refer to CCl₄ solutions unless otherwise indicated. MS = mass spectrum (*m/z*). ^d Known compound.⁷ ^e Known compound.⁸ ^f In tetrachloroethene. ^g Available in high yield by bromination of phenylacetylene; ref 9. ^h The isolated sample contained a trace amount of an unidentified impurity which was not removed by column chromatography or vacuum distillation. ⁱ This compound was not obtained free of tetrabromoethene. Yield determined by NMR with dichloromethane as internal standard.

Results and Discussion

Synthesis of 5 from acetone phenylhydrazone by the procedure of Schulz and co-workers⁵ is outlined in eq 6. The corresponding

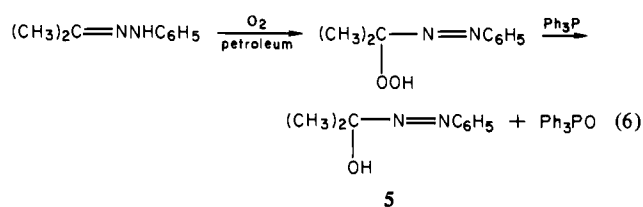

route to 6 failed at the oxygenation step, but 6 could be prepared readily by the route outlined in eq 7. The latter route also works

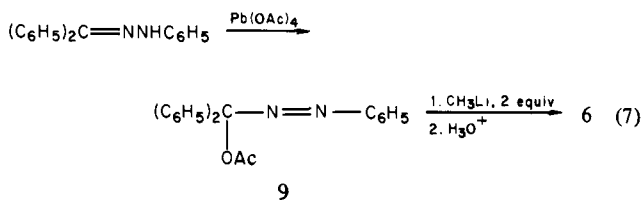

for 5, but the first route, which is less costly, is preferable in cases where either route works. Azocarbinol 7 was prepared from cyclohexanone azine as shown in eq 8, following the general procedure of Gillis and LaMontagne⁶ for the first step.

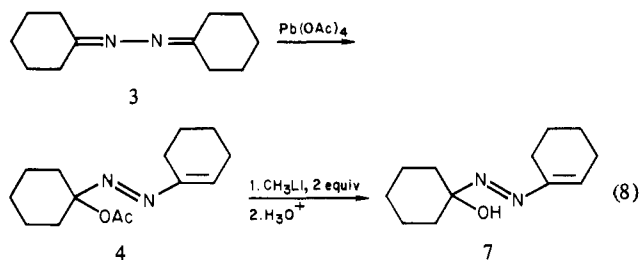

(3) (a) Knittel, P.; Warkentin, J. *Can. J. Chem.* 1975, 53, 2275. (b) Yeung, D. W. K.; Warkentin, J. *Ibid.* 1976, 54, 1349. (c) Nazran, A. S.; Warkentin, J. *J. Am. Chem. Soc.* 1981, 103, 236.
(4) (a) Knittel, P.; Warkentin, J. *Can. J. Chem.* 1976, 54, 1341. (b) Yeung, D. W. K.; Warkentin, J. *Ibid.* 1976, 54, 1345. (c) *Ibid.* 1980, 58, 2386.

(5) Schulz, M.; Missol, U.; Bohm, H. *J. Prakt. Chem.* 1974, 316, 47.
(6) Gillis, B. T.; LaMontagne, M. P. *J. Org. Chem.* 1967, 32, 3318.

Azocarbinols 5, 6, and 7 decompose smoothly in solution at temperatures between 25 and 80 °C. Radical mechanisms for decomposition of 5, 6, and 7 in carbon tetrachloride were indicated by the formation of the products shown in eq 9–11 (compounds 5 or 6) and eq 12–14 (compound 7) (Experimental Section).

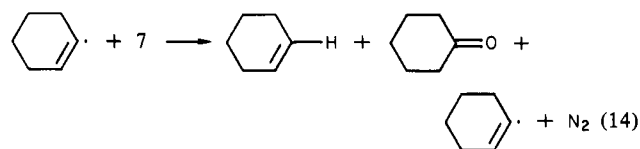
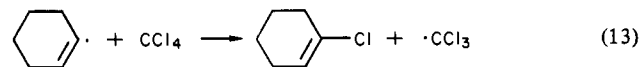
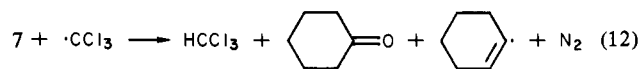
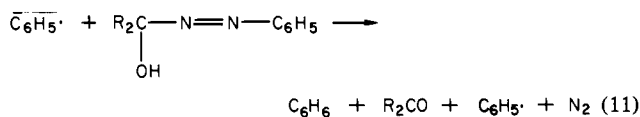
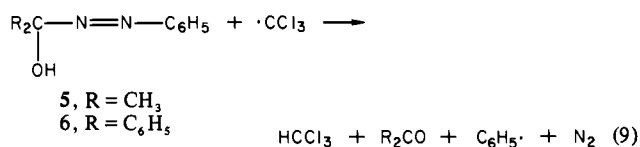

Thermolysis of 6 or 7 in neat polyhaloethenes gave the hydro-1-cyclohexenylation or hydrophenylation products of Table I. Azocarbinol 5, in trichloroethene, gave results similar to those from decomposition of 6 in that solvent. Potential advantages of 5 over 6 as a hydrophenylating agent include the simplicity and low cost of preparing 5 (see above) and the easier removal of the byproduct: acetone from 5 vs. benzophenone from 6.

The addition reactions with 5, 6, and 7, like the substitution chemistry of eq 9–14, are readily explained in terms of radical

(7) Reynolds, W. F.; Wood, D. *J. Can. J. Chem.* 1971, 49, 1209.

(8) Bodrikov, I. V.; Sokova, F. M.; Maleva, V. N. *Zh. Org. Khim.* 1973, 9, 1428.

(9) Newman, M. S.; Connor, E. H. *J. Am. Chem. Soc.* 1950, 72, 4002.

Table II. Kinetics of Thermal Decomposition of Azocarbinols and Derivatives

compd	reaction conditns ^a	rate constant ^b
Ph ₂ C(OH)N=NPh ^c (6)	CCl ₄ , 80.0 ± 0.1 °C	2.5 × 10 ⁻⁴ s ⁻¹
Ph ₂ C(OMe)N=NPh ^d (9)	CCl ₄ , 80.0 ± 0.1 °C	3.6 × 10 ⁻⁶ s ⁻¹
Ph ₂ C(OAc)N=NPh ^d (10)	CCl ₄ , 80.0 ± 0.1 °C	1.2 × 10 ⁻⁶ s ⁻¹
(CH ₃) ₂ C(OH)N=NPh (5)	CCl ₄ , 35.0 ± 0.1 °C	7.4 × 10 ⁻⁴ s ⁻¹
(CH ₃) ₂ C(OH)N=NPh (5)	PhH, 35.0 ± 0.1 °C	4.0 × 10 ⁻⁶ s ⁻¹
(CH ₃) ₂ C(OAc)N=NPh (8)	CCl ₄ , 80.0 ± 0.1 °C	3 × 10 ⁻⁸ s ⁻¹ ^e
(CH ₃) ₂ C(OH)N=NPh (5)	PhSH (1.0 × 10 ⁻³ M) in CCl ₄ , 35.0 ± 0.1 °C	3.2 × 10 ⁻³ s ⁻¹
(CH ₃) ₂ C(OH)N=NPh (5)	PhSH (5.0 × 10 ⁻⁴ M) in CCl ₄ , 35.0 ± 0.1 °C	1.6 × 10 ⁻³ s ⁻¹
(CH ₃) ₂ C(OH)N=NPh ^f (5)	PhCHO (0.4 M) in PhH, 35.0 ± 0.1 °C	2.3 × 10 ⁻⁵ M ⁻¹ s ⁻¹
(CH ₃) ₂ C(OH)N=NPh ^d (5)	PhCHO (2 M) in PhH	6.0 × 10 ⁻⁵ s ⁻¹ (3.0 × 10 ⁻⁵ M ⁻¹ s ⁻¹)
(CH ₃) ₂ C(OH)N=NPh ^d (5)	PhCHO (5 M) in PhH	1.6 × 10 ⁻⁴ s ⁻¹ (3.2 × 10 ⁻⁵ M ⁻¹ s ⁻¹)
(CH ₃) ₂ C(OH)N=NPh ^d (5)	PhCHO (9.8 M, neat), 5 (0.05 M)	2.7 × 10 ⁻⁴ s ⁻¹ (2.8 × 10 ⁻⁵ M ⁻¹ s ⁻¹)
(CH ₃) ₂ C(OH)N=NPh (5)	Ph ₃ C· (7.4 × 10 ⁻² M), ^g trityl dimer (0.32 M), PhH, 35.0 ± 0.1 °C	3.7 × 10 ⁻⁵ s ⁻¹ ^c (2.6 × 10 ⁻³ M ⁻¹ s ⁻¹) ^h
(CH ₃) ₂ C(OH)N=NPh (5)	12 (0.12 M), 5 (0.012 M), PhH, 35.0 ± 0.1 °C	9.7 × 10 ⁻⁷ s ⁻¹ (8.1 × 10 ⁻⁶ M ⁻¹ s ⁻¹)
(CH ₃) ₂ C(OH)N=NPh (5)	13 (0.15 M), 5 (0.015 M), PhH, 35.0 ± 0.1 °C	8.4 × 10 ⁻⁶ s ⁻¹ (5.6 × 10 ⁻⁵ M ⁻¹ s ⁻¹)

^a The reactions were followed by ¹H NMR, unless otherwise specified, using degassed solutions in sealed tubes containing an internal standard for integration (Experimental Section). ^b Rate constants are averages of at least two runs, except as noted, and are subject to errors of ±10%. First-order rate constants and pseudo-first-order rate constants are in s⁻¹. The latter are followed by the second-order rate constant (M⁻¹ s⁻¹) in brackets. ^c Followed by monitoring the intensity of the benzophenone carbonyl band in the IR spectrum. ^d Single run. ^e Followed to 20% of completion only. The rate constant was calculated on the basis of assumed first-order kinetics. ^f Run under second-order conditions with initial concentrations of azocarbinol and benzaldehyde both at 0.4 M. ^g Pseudo-first-order conditions because trityl dimer, in large excess over 5, keeps the concentration of Ph₃C· constant. The equilibrium constant for dimer ⇌ 2 trityl was estimated from ref 16 to be 7.5 × 10⁻⁴ M at 35 °C (extrapolated to 35 °C). ^h Since the concentration of trityl was calculated from the concentration of trityl chloride precursor and the equilibrium constant (footnote g), it is probably a maximum value and the bimolecular rate constant may therefore be a minimum value. That rate constant is probably no better than a guide to the order of magnitude, because of the assumptions involved in calculating the steady-state concentration of trityl.

chain, induced decomposition of those compounds.¹⁰ Equation 15–17 show the appropriate chain-carrying steps for one case.

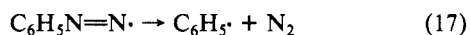
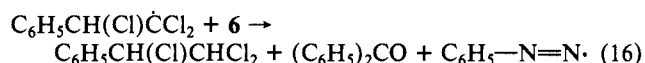
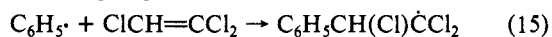

However, there are alternative mechanisms that have to be considered. The azocarbinols might be decomposing reversibly according to eq 18 or 19, and the observed chemistry might be

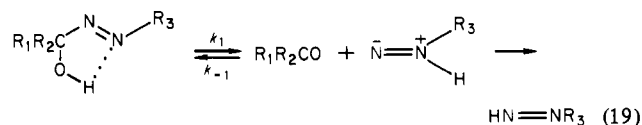
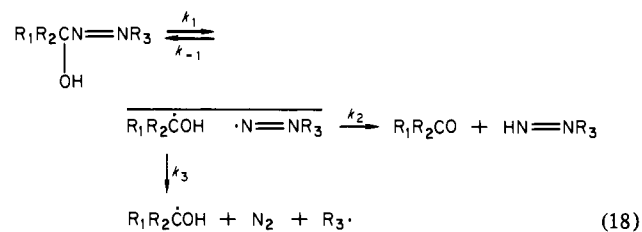

accounted for in terms of subsequent reactions of free radicals (eq 18) and/or diazenes (eq 18 and 19). Although 1-substituted 1H-diazenes (eq 19) are unknown, they have been considered as possible intermediates in the formation of 1-substituted 2H-diazenes.¹¹

These alternative, nonchain mechanisms for decomposition of azocarbinols are particularly worthy of consideration in view of reports^{12,13} that azocarbinols react with ketones to form new

azocarbinols and with aldehydes to form hydrazides via azocarbinols (eq 20 and 21) Since monosubstituted diazenes,

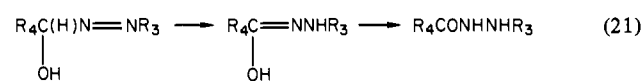
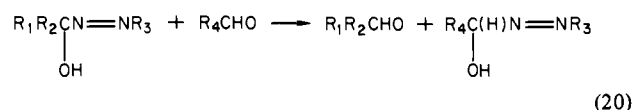

generated independently of azocarbinol sources, react with aldehydes to give the same products,^{2f} it has been assumed that the azocarbinol-aldehyde reaction (eq 20) involves HN=NR₃ as an intermediate.

We carried out three types of experiments to probe into the mechanism by which azocarbinols decompose. First, rate constants for thermolysis of 5 and 6 and their methylated (9) and acylated (8, 10) analogues were measured. If eq 18 were applicable, with

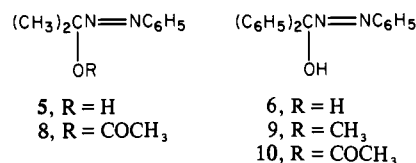

the *k*₁ step rate determining, then 5 and 8, on the one hand, and 6, 9, and 10, on the other hand, should decompose at comparable rates. Second, we tried to establish whether or not the azocarbinol-aldehyde reaction (eq 20) goes through a monosubstituted diazene intermediate (either 1H or 2H) when carried out in neutral medium.¹⁴ Third, we looked for evidence of attack of three persistent free radicals, 11, 12, and 13, on 5 under conditions where 5 is reasonably stable by itself.

Kinetics of Thermolysis of 5, 8, 6, 9, and 10. The five compounds decomposed with first-order kinetics in benzene and in CCl₄ with rate constants given in Table II. These substituent

(10) Radical chain additions of R-H (where R = aryl or 1-alkenyl) to alkenes to form small molecules have not been reported. Reviews of other free radical additions to form small molecules include: (a) Walling, C.; Huyser, E. S. *Org. React.* **1963**, *13*, 91. (b) Stacey, F. W.; Harris, J. F. *Ibid.* **1963**, *13*, 150. (c) Sosnovsky, G. "Free Radical Reactions in Preparative Organic Chemistry"; MacMillan: London, 1964. (d) Griesbaum, K. *Angew. Chem., Int. Ed. Engl.* **1970**, *9*, 273. (e) Neale, R. S. *Synthesis* **1971**, *1*, 1. (f) Abell, P. I. "Free Radicals"; Kochi, J. K., Ed.; Wiley: New York, 1973; Vol. 2. (g) Minisci, F. *Acc. Chem. Res.* **1975**, *8*, 165.

(11) Huang, P.-k. C.; Kosower, E. M. *J. Am. Chem. Soc.* **1968**, *90*, 2362.

(12) Schulz, M.; Missol, U. *Zeit. Chem.* **1974**, *14*, 265.

(13) Büttner, G.; Hüning, S. *Chem. Ber.* **1971**, *104*, 1104.

(14) There is no doubt that azocarbinols decompose to carbonyl compounds and diazene at pH ≥ 10¹³ or under the influence of acid catalysts.^{12,15}

(15) Freeman, J. P.; Rathjen, C. P. *J. Org. Chem.* **1972**, *37*, 1686.

(16) Colle, T. H.; Glaspie, P. S.; Lewis, E. S. *J. Org. Chem.* **1978**, *43*, 2722.

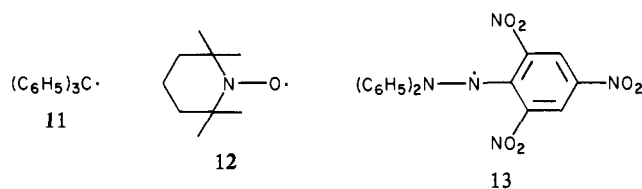

effects on the kinetics are not compatible with eq 18 if the first step is rate determining and irreversible for then **5** and **8** as well as **6**, **9**, and **10** should be similar with rate factors like those observed for **9** and **10**. The enhanced rate of decomposition of **5** and **6** might be accounted for in two ways. First, the initial step of eq 18 could apply for all five compounds, with **8**, **9**, and **10** reacting slowly because of extensive recombination.¹⁷ Recombination of radicals from **5** or **6** might well be suppressed, not because of a small k_{-1} but because of a large k_2 . Second, the azocarbinols might use a different mechanism not available to the ether or ester derivatives. This different mechanism could be that of eq 19 or it might be the radical chain mechanism of eq 9–11.

The effects of added thiophenol, on the rate of decomposition of **5**, favor the latter explanation (Table II). Compounds **8**–**10** do not show rate enhancement from the added thiol, indicating that if eq 18 applies there is no scavenging of radicals from a caged pair at the concentrations that were used (Table II). However, **5** decomposes appreciably faster in the presence of thiophenol at low concentration (Table II) than in its absence. If the thiol is not scavenging caged pairs from **8**, it can not be doing so in the case of **5** either. The rate enhancement must therefore arise by a mechanism other than suppression of the reverse of a homolysis step. Unfortunately we have no information about the properties of 1-substituted 1*H*-diazenes (eq 19) and we can not predict how well (or whether) thiophenol would catalyze their isomerization to 1-substituted 2*H*-diazenes. Although we can not firmly exclude that mechanism (eq 19) at this time, it is not easy to see how it can be made compatible with chain character,¹⁸ except as a way of initiating chain steps like those of eq 9–11.

A mechanism that can accommodate the influence of CCl_4 and of thiophenol is induced decomposition (eq 9–11), provided that $\cdot\text{CCl}_3$ and $\text{PhS}\cdot$ can act as chain carriers. We have previously suggested a similar possibility to account for the fact that phenol enhances rates and yields of radical chain hydroalkylation reactions;⁴ eq 22, for example. In that case the thermochemistry of

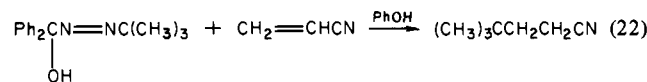

induced decomposition could be particularly favorable if the abstraction step were fully concerted, forming a carbonyl group, N_2 , and a tertiary radical.

In the case of **5**, **6**, and **7**, where azo nitrogen is bound to sp^2 carbon, a fully concerted, induced decomposition step is less likely. Phenyl diazenyl radicals from **5** and **6**, and 1-cyclohexenyldiazenyl radicals from **7**, are likely intermediates.^{17,19} However, even for partly concerted H abstraction from **5** by $\text{C}_6\text{H}_5\text{S}\cdot$ (eq 23) ΔH is negative.²¹ Chain carrying by $\text{C}_6\text{H}_5\text{S}\cdot$ is therefore plausible

(17) Porter, N. A.; Dubay, G. R.; Green, J. G. *J. Am. Chem. Soc.* **1978**, *100*, 920.

(18) The evidence for a chain mechanism in the present azocarbinol systems hinges largely on the faster rates in CCl_4 as compared to rates in benzene and on the rate enhancement by thiophenol. Inhibition was not realized, except for the very mild retardation by **12** (Table II). In another azocarbinol system, we have found effective inhibition,^{3c} and we lean slightly on analogy in claiming chain character in the cases of **5** and **6**.

(19) There is essentially no extra enthalpic driving force from breaking the azo-to-phenyl bond, for the loss of N_2 is approximately thermoneutral.²⁰

(20) Engel, P. S.; Wood, J. L.; Sweet, J. A.; Margrave, J. L. *J. Am. Chem. Soc.* **1974**, *96*, 2381.

(21) Using the following approximate bond energies, we estimate ΔH for eq 23 to be -37 kcal mol^{-1} . Bond energies (kcal mol^{-1}): O–H (105), C–O (≤ 70), C– N_{azo} (47), C=O (179), S–H (≥ 80), estimated from values in "Handbook of Chemistry and Physics", 61st ed.; Weast, R. C., Ed.; CRC Press: Boca Raton, FL, 1980–1981.

Table III. Product Ratios from Thermolysis of **6** in CCl_4 ^a

initial [6], M	PhCl/PhH ^b	PhCl/CHCl ₃ ^b
0.60	1.4	0.96
0.35	2.9	0.98
0.26	3.8	1.1
0.17	6	0.7
0.09	11	1
0.04	24	0.5
0.01	large ^c	0.8

^a All reactions were carried to completion before product analysis by gas chromatography. The ratios have been corrected for differences in detector response. ^b The most reliable ratios are the first three, for the high initial concentrations of **6**. ^c Benzene not detected.

because many efficient radical chain reactions have one or more slightly endothermic chain-carrying steps.

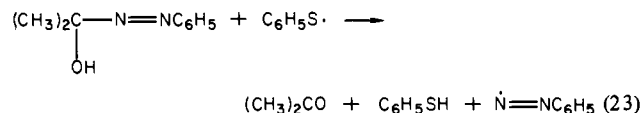

Azocarbinol–Aldehyde Reaction. It was pointed out above that the reaction of azocarbinols with ketones to form new azocarbinols and with aldehydes to form hydrazides (eq 20 and 21) has been interpreted in terms of a mechanism involving monosubstituted diazene intermediates,^{12,13} (eq 24 and 25). The mechanism (i.e.,

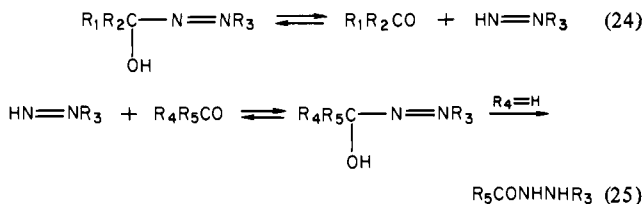

eq 18 or 19 or other) by which the diazene is supposed to be generated in the absence of acid or base is not clear, and there is disagreement concerning the addition of diazenes to ketones. Kosower and Huang²² claimed that phenyldiazene does not add to reactive carbonyl compounds like methyl chloroformate and Hünig, Büttner, and co-workers^{2d–8} were not able to add alkyl-diazenes to ketones. However, Schulz and Missol¹² use the above mechanism to account for the interconversion of hydroxydiazenes in the presence of ketones under neutral conditions.

The kinetics of disappearance of **5** in the presence of benzaldehyde in benzene was revealing (Table II). The reaction is second order overall, first order in **5**, and first order in benzaldehyde over a large range of aldehyde concentrations. This result can not be accommodated with diazene formation via eq 18. If one postulates that phenyldiazene does react with acetone; that is, if a reversible k_2 step is assumed, then a levelling effect should be observed at high aldehyde concentrations, where ketone can no longer compete with aldehyde for the diazene. However, there is no sign of a levelling off of the rate up to neat benzaldehyde. A similar argument applies to the mechanism of eq 19. Unless ketone is much more reactive than aldehyde toward 1-substituted 1*H*-diazene (an unlikely situation), there ought to be a limiting concentration of aldehyde beyond which the rate no longer depends on aldehyde concentration. We are therefore led to the suggestion that there may be a direct reaction between **5** and benzaldehyde and that diazenes are not necessarily intermediates in processes by which azocarbinols react with carbonyl compounds to form new azocarbinols.²³ Specifically, the fact that the chemistry of eq 20 and 21 occurs between **5** and benzaldehyde does not appear

(22) Huang, P. C.; Kosower, E. M. *J. Am. Chem. Soc.* **1968**, *90*, 2367.

(23) Diazene intermediates are more likely from decomposition of azocarbinols under acidic or strongly basic conditions.¹⁴ Care was taken (Experimental Section) to ensure that the benzaldehyde was free from benzoic acid and that the solvent was neutral. More detailed study of the reaction between **5** and aryl aldehydes is in progress.

to be in conflict with the radical chain mechanisms proposed for thermolyses in CCl_4 , in benzene, or in haloethenes.

Finally, the experiments with long-lived free radicals and **5** (Table II) provide support for induced decomposition of the latter. The usual result of addition of a persistent radical to a system undergoing chain reaction is that chains are stopped. That is, the persistent radical captures nonpersistent radicals and prevents them from chain carrying, causing an induction period which lasts until all the scavenger has been consumed. The results of exposing **5** to benzene solutions of **11**, **12**, and **13** are contrary to that expectation. Trityl radical (**11**) accelerates the decomposition of **5** considerably, while diphenylpicrylhydrazyl (**13**) accelerates weakly and 2,2,6,6-tetramethylpiperidinyl-1-oxy (**12**) retards weakly. In the case of another azocarbinol,^{3c} both **12** and **13** act as true inhibitors. Although a full explanation of these phenomena with **5** is not possible at this stage, it is hard to argue that **11**, **12**, and **13** fail to trap phenyl radicals or radicals resulting from addition of phenyl to the solvent benzene. Given that they do trap such radicals, it is difficult to account for their acceleration of the decomposition rate or for their failure to inhibit effectively, unless it is assumed that the persistent radicals themselves can induce decomposition of **5**.²⁴

Abstraction of H from **5** by trityl²⁵ implies that **5** is a very good chain-transfer agent. Similarly, the fact that **6** can compete with CCl_4 for phenyl radicals (Table III) implies that **6** also is an excellent chain-transfer agent. In view of these results, the chain-propagating, H-abstraction steps postulated in eq 12 and 16, for example, become quite plausible.

The results with **5**, **6**, and **7** illustrate that the azocarbinol system provides enough driving force to make feasible the generation of a relatively unstable radical (aryl or vinyl) by H abstraction with a relatively stable radical, such as $\text{ArCCl}_2\text{CCl}_2$. Although extrapolations cannot be made with full confidence, it is likely that the azocarbinol system will lend itself to the generation and application of a variety of other radicals (e.g., $\cdot\text{CN}$ and $\cdot\text{C}\equiv\text{CR}$) provided that the necessary precursors can be obtained.

All cases of additions to unsymmetric alkenes led to only one of the possible structurally isomeric adducts. This result could mean simply that phenyl and 1-cyclohexenyl radicals are quite selective in attacking an unsymmetrically substituted π system. However, there is an interesting mechanistic ambiguity here. The first intermediate from addition of a $\text{C}(\text{sp}^2)$ radical to an alkene is of the homoallyl radical type. Many examples of facile rearrangement of such radicals, through cyclopropylcarbinyl radical intermediates to isomeric homoallyl radicals, have been reported.²⁶ Thus, it is possible that the observed ratio of products (P_1/P_2) does not reflect kinetic control (k_1/k_2) at all (eq 26).²⁷

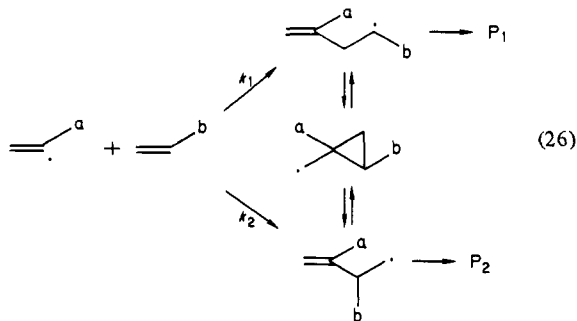

(24) The net effect of adding persistent radical to an azocarbinol system might be expected to range all the way from complete inhibition, through partial inhibition, to acceleration depending on the rate constant for induced decomposition of azocarbinol by the persistent radical and upon the concentration of the latter. Further experiments are in progress.

(25) Trityl radical abstracts H from thiophenol with rate constant $13.5 \text{ M}^{-1} \text{ s}^{-1}$ at 40°C .¹⁶

(26) The subject has been reviewed recently. Beckwith, A. L. J.; Ingold, K. U. In "Rearrangements in Ground and Excited States"; de Mayo, P., Ed.; Academic Press, New York, 1980.

(27) The probability of rearrangement of first-formed adduct radicals will depend on the rate constant for rearrangement (much smaller for homobenzylic radicals than for homoallyl radicals²⁶) and on the rates of competing processes.

We do not have any information concerning rearrangements in the reactions of **5**, **6** and **7** which are reported here, but we wish to draw attention to the problem. It is interesting that this problem, which exists also for the much studied Meerwein reaction,^{28,29} apparently has not been discussed in papers and reviews on the subject.

According to one report,³⁰ tetrachloroethene does not react under Meerwein conditions that lead to haloarylation of many other chlorinated alkenes. Our results indicate that such failure cannot be attributed to the radical addition step, for phenyl radicals from **6** do add to tetrachloroethene. We suggest that phenyl radicals can add also under Meerwein conditions and that the failure to find the expected Meerwein product from tetrachloroethene may be attributed either to chlorine atom loss from the adduct (eq 27) or to other competitive processes which depress

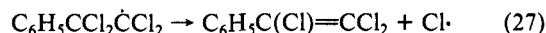

the overall yield in the Meerwein reaction. Fast halogen loss (e.g., eq 27) might account for the low yields obtained in additions to tetrachloro- and tetrabromoethene (Table I).

Experimental Section

2-(Phenylazo)-2-propanol (5) by Air Oxidation. Freshly prepared acetone phenylhydrazone (7.4 g, 0.05 mol) was dissolved in petroleum ether (200 mL), and the stirred solution, at room temperature, was exposed to oxygen delivered from a gas burette at about 1-atm pressure. When oxygen uptake was complete, a *small* aliquot was removed, the solvent was stripped off under vacuum without heating above room temperature, and the residue was examined by ^1H NMR spectroscopy. There was a singlet at δ 1.45 attributed to 2-(phenylazo)-2-propyl hydroperoxide, but no evidence of unreacted hydrazone, which gives rise to singlets at δ 1.73 and 1.97.

The bulk of the petroleum ether solution was added to a solution of triphenylphosphine (13.0 g, 0.05 mol) in petroleum ether (400 mL). The precipitate of triphenylphosphine oxide (mp $153\text{--}154^\circ\text{C}$) which had formed overnight was filtered off, and the solvent was evaporated without heating to give **5** (82%) as an unstable yellow oil. This material was used directly for hydrophenylation of alkenes, but it was distilled, from a pot in ice water to a receiver in liquid N_2 , at 10^{-2} torr, for material to be used for kinetics: ^1H NMR (CCl_4) δ 1.45 (6 H, s), 4.30 (1 H, br s, OH), 7.40 (5 H, m). Vigorous decomposition occurred sometimes during acquisition of the NMR spectrum, particularly if the CCl_4 had not been base-washed, distilled, and cooled.

2-(Phenylazo)-2-Propanol (5) by Oxidation with Pb^{IV} . 2-Acetoxy-2-(phenylazo)propane (**8**) prepared by oxidation of acetone phenylhydrazone with lead tetraacetate³¹ was deacylated with 2-equiv of methylithium in ether as previously described for analogues.^{3a,b} Hydrolysis of the lithium salt with saturated NH_4Cl solution, extraction with ether, drying, and evaporation of the solvent at or below room temperature left **5** as a viscous yellow-to-brown oil. Distillation, as described above, gave material identical with that from the autooxidation route.

(Phenylazo)diphenylmethyl Acetate (9). A solution of benzophenone phenylhydrazone (27.2 g, 0.10 mol) in dichloromethane (100 mL) was added in the course of 15 min to a stirring solution of lead tetraacetate (49.0 g, 0.11 mol) in 200 mL of dichloromethane at $0\text{--}10^\circ\text{C}$. After the solution was stirred for 15 min more, the precipitate which had formed was filtered off and the liquid phase was washed successively with water and with 5% sodium bicarbonate solution until it was free of acetic acid. Drying over anhydrous sodium sulfate followed by evaporation of the solvent with a rotary evaporator left a viscous yellow oil which, upon trituration with light petroleum ether, gave yellow crystals of **9** (27.0 g, 82%). Recrystallization from pentane gave material melting at $100\text{--}101^\circ\text{C}$ (lit.³¹ $101\text{--}103^\circ\text{C}$).

(Phenylazo)diphenylmethanol (6). The deacylation procedure for **8** was followed. Treatment of **9** (3.3 g, 0.01 mol) in 100 mL of ether with 14 mL of 1.84 M methylithium in ether (0.025 mol of CH_3Li) afforded yellow, crystalline **6** (2.0 g, 70%, recrystallized from petroleum ether): mp $75\text{--}76^\circ\text{C}$ dec; ^1H NMR (CCl_4) δ 7.1–7.8 (m, 15 H, aromatic), 5.83 (s, 1 H, OH); IR (CCl_4) 3381 cm^{-1} (OH). This azocarbinol was stable

(28) Rondestvedt, C. S., Jr. *Org. React.* **1976**, *24*, 225.

(29) Rondestvedt, C. S., Jr. *Org. React.* **1960**, *11*, 189.

(30) Dombrovskii, A. V.; Naidan, U. M. *J. Gen. Chem. USSR (Engl. Transl.)* **1962**, *32*, 1256.

(31) Iffland, D. C.; Salisbury, L.; Schafer, W. R. *J. Am. Chem. Soc.* **1961**, *83*, 747.

enough to be mailed for analysis. Anal. Calcd for $C_{19}H_{16}N_2O$: C, 79.17; H, 5.56; N, 9.72. Found: C, 79.35; H, 5.83; N, 9.64.

Methyl (Phenylazo)diphenylmethyl Ether (10). Oxidation of benzophenone phenylhydrazone with lead tetraacetate, as described above for preparation of **9**, but with dry methanol as solvent instead of dichloromethane afforded **10** (75%) as yellow crystals: mp 93–95 °C; 1H NMR (CCl_4) δ 3.91 (3 H, s), 7.1–7.8 (15 H, m); mass spectrum m/z 302, calcd for $C_{20}H_{18}N_2O$, m/z 302.

1-(1-Cyclohexenylazo)cyclohexyl Acetate (4). A modification of the procedure of Gillis and La Montagne⁶ gave satisfactory results. To a stirring solution of cyclohexanone azine (15.7 g, 0.08 mol) in benzene (250 mL) cooled with an ice bath was added, slowly, lead tetraacetate (47.7 g, 0.1 mol, 95% pure). Stirring was continued while the mixture was allowed to warm to room temperature during 2 h. Filtration to remove a precipitate, washing of the benzene solution several times with water and with saturated sodium bicarbonate solution, drying with sodium sulfate, and evaporation of the benzene under reduced pressure left an orange oil which was chromatographed on a silica gel column with 10% ethyl acetate in cyclohexane. The first fraction eluted was **4**: a yellow oil (10.4 g, 51%) with spectra matching those reported.⁶

1-(1-Cyclohexenylazo)cyclohexanol (7). A stirring solution of **4** (2.5 g, 0.01 mol) in 100 mL of anhydrous ether, under nitrogen, was cooled to –10 °C with an ice-salt bath. Methylithium (0.022 mol, 12 mL of 1.84 M CH_3Li in ether) was dropped in from a syringe during 10 min. After the mixture was stirred for 15 min more, cold saturated ammonium chloride solution (100 mL) was added slowly. The organic layer was separated, the aqueous layer was extracted twice with ether, and the combined extract was dried over sodium sulfate.

Removal of the solvent with a rotary evaporator, without heating, left **7** as an unstable yellow oil (1.1 g, 53%): 1H NMR (CCl_4) δ 6.82 (t, J = 4.0 Hz, 1 H, vinyl); 4.73 (br s, 1 H, hydroxyl); 1.4–2.6 (m, 18 H, CH_2); IR (neat) 3390 (OH), 1650 and 1635 ($C=C$, $N=N$) cm^{-1} .

Thermolysis of 7 in CCl_4 . A solution of **7** (0.416 mg, 2.0 mmol) in CCl_4 (6 mL) was refluxed for 1 h. Bulb to bulb distillation separated volatile products from a high-boiling, unidentified residue. The distillate was analyzed by GLPC with an Aerograph A90-P3 instrument fitted with a 10 ft \times 0.25 in. column (Carbowax 20M, 15%, on 60–80 mesh Chromosorb A) operating at 130 °C with a helium flow rate of 60 mL min^{-1} . The volatile products were chloroform (66%), 1-chlorocyclohexene (66%), cyclohexanone (69%), and cyclohexene (5%); each percentage was based on **5**. Yields were estimated from the chromatograms by using chlorobenzene as internal standard without correction for differences in thermal conductivities. Identity was confirmed in each case by comparing IR spectra, 1H NMR spectra, and retention times of materials from the column with those of authentic samples.

Thermolysis of 6 in CCl_4 . Analogous decomposition of **6** in CCl_4 was accompanied by a change in color from yellow to orange-red. Separation of the volatile components from benzophenone and other high-boiling material by distillation under reduced pressure and analysis of the volatile material by GLPC showed the presence of chlorobenzene, benzene, and chloroform (ratios in Table III). Identity was confirmed by glpc, with authentic solutions of those products in CCl_4 , and by IR of the mixture. All major bands of the composite spectrum corresponded to bands in the spectra of one or more of the individual components.

The distillation residue was subjected to bulb-to-bulb distillation/sublimation in a Kugelrohr apparatus. Material which volatilized at ca. 1 mm (100 °C) was identified as benzophenone (mp, IR). A small amount of residue was not examined.

Thermolysis of 7 in Haloalkenes. The procedure for reaction of **7** with trichloroethene is described. Variations of the procedure in other syntheses with **7** are listed in Table I and its footnotes.

A solution of **7** (1.04 g, 5.0 mmol) in 8 mL of freshly distilled trichloroethylene was held at reflux for 30 min. Evaporation of excess trichloroethene under reduced pressure left a dark brown residue, which was chromatographed on silica gel by using petroleum ether (bp 30–60 °C). The colorless oil that was obtained (246 mg, 23%) was identified as 1,1,2-trichloro-2-(1-cyclohexenyl)ethane. Its spectra are in Table I.

Thermolysis of 6 in Haloalkenes. The procedure for reaction of **6** with trichloroethene is described. Variations of the procedure for other synthesis with **6** are listed in Table I and its footnotes.

Trichloroethene (5 mL) was added from a syringe to **6** (576 mg, 2.0 mmol) in a septum-stoppered flask vented with a syringe needle. Vigorous gas evolution was observed. After a 1-h period at room temperature, the excess trichloroethene was removed under reduced pressure and the residual oil was chromatographed on silica gel (60–120 mesh) by using CCl_4 as eluant. The known⁷ 1,1,2-trichloro-2-phenylethane was obtained as a colorless oil (200 mg, 48%).

Kinetics of Thermal Decompositions. Carbon tetrachloride and benzene for kinetics were washed with sodium bicarbonate solution and stored over anhydrous sodium carbonate in brown bottles. Distillation

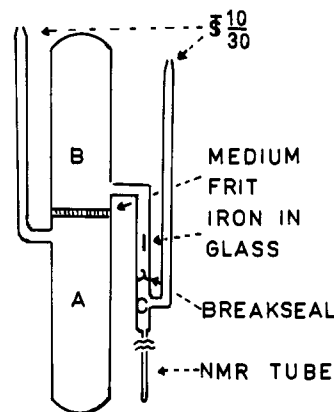

Figure 1. Apparatus for Generation of Trityl Radicals and for their reaction with **5**.

just before use did not affect the kinetics and was sometimes omitted for duplicates.

The decompositions of all compounds in Table II, except for **6**, were followed by 1H NMR. Azo compounds (20–30 mg) were weighed into carbonate-washed NMR tubes sealed to ground glass joints. Solvent and internal standard for integration were introduced from syringes, or they were vaporized into the NMR tube on the vacuum line. The contents of the tube were then degassed with at least four freeze-pump-thaw cycles at 10^{-2} torr or lower pressure before the tube was sealed.

For reactions at 80 °C, tubes were immersed in an oil bath. Data were taken by chilling the tube quickly, warming up to room temperature, and integrating at least four times with a Varian t-60 or a Varian EM-390 NMR spectrometer (probe temperatures 35 ± 0.5 °C). Time outside the oil bath was not counted. For reactions at 35 °C a water bath was used between analyses and time in the NMR instrument was counted.

Four or more integrals of the signals from a CH_3 group of the substrate and from internal standard were averaged and the integral for substrate was normalized by using that from internal standard as reference. The reactions were followed to at least 3 half-lives, and correlation coefficients for fits to the first-order (or pseudo-first-order) rate law were usually 0.99 or better, with one (for **10**, Table II) as low as 0.97.

Kinetics of Reaction of 5 with Benzaldehyde. Reagent grade benzaldehyde was shaken thoroughly with sodium bicarbonate solution and with water, dried with Na_2SO_4 , and distilled under nitrogen. It was stored under nitrogen.

Solutions of **5**, benzene, benzaldehyde, and internal standard dimethyl carbonate, in sealed NMR tubes, were prepared by the procedure described above. Distillation of the last three components directly onto **5** on the vacuum line did not alter the kinetics. For the most dilute solution (Table II) the second-order rate equation was applied. In the other cases benzaldehyde was in sufficient excess (>10:1) to assure pseudo-first-order behaviour.

Product of Reaction of 5 with Benzaldehyde. A solution of **5** (0.75 g, 4.6 mmol) in benzaldehyde (7.7 mL) was degassed and sealed into a thick-walled tube which was kept at 35 °C for 48 h. The solid which had precipitated was filtered off and washed with petroleum ether to leave crude 1-benzoyl-2-phenylhydrazine (1.0 g, 77%): mp 165–167 °C (lit.³² mp 168 °C); mass spectrum m/z 212.

Reaction of 5 with Trityl Radicals. The apparatus for the experiments with trityl is sketched in Figure 1. Triphenylchloromethane (2.4 g, 8.6 mmol) in benzene (10 mL) and mercury (5.0 g, 24.9 mmol) were introduced into compartment A, and the pumping arm was sealed off after four freeze-pump-thaw cycles at 5×10^{-3} torr. The apparatus was mounted at a nearly horizontal attitude on a mechanical shaker, and it was shaken for 48 h at room temperature, following (roughly) the procedure of Hammond and co-workers.³³

Azocarbonyl **5** (0.98 g, 0.60 mmol) in benzene (3.0 mL) containing dimethyl carbonate was introduced into compartment C which was sealed off after the degassing procedure. The trityl solution was filtered through the frit into compartment B by cooling the latter, the breakseal was ruptured, and the solutions in C and B were mixed thoroughly. The system was kept cold during the mixing. An aliquot of the final solution was then sealed into the NMR tube attached to compartment C, and the tube was separated and warmed to 35 °C for kinetics. The presence of trityl radicals, both at t_0 and at t_{∞} , was confirmed by ESR, but the initial trityl concentration was calculated from the amount of trityl chloride

(32) Autenrieth, W.; Thomas, G. *Chem. Ber.* **1924**, *57*, 423.

(33) Hammond, G. S.; Ravve, A.; Modic, F. *Anal. Chem.* **1952**, *24*, 1373.

introduced, the total volume, and the equilibrium constant for dimer \rightleftharpoons 2 trityl,¹⁶ by assuming 100% yield for the reduction of trityl chloride.

Kinetics of Reaction of 5 with 12 and 13. Radicals 12 and 13 were used as received from the Aldrich Chemical Co. The appropriate solutions of 5 and 12 (or 13) in benzene containing dimethyl carbonate as internal standard were degassed and sealed into NMR tubes as already

described above for analogous experiments.

Acknowledgment is made to the donors of the Petroleum Research Fund, administered by the American Chemical Society, and to the Natural Sciences and Engineering Research Council of Canada for support of this work.

Synthesis and Properties of 12-Fluororetinal and 12-Fluororhodopsin. A Model System for ¹⁹F NMR Studies of Visual Pigments

Robert S. H. Liu,*[†] Hiroyuki Matsumoto, Alfred E. Asato, Marlene Denny, Yoshinori Shichida, Toru Yoshizawa, and F. W. Dahlquist

Contribution from the Department of Chemistry, University of Hawaii, Honolulu, Hawaii 96822, Department of Biophysics, Faculty of Science, Kyoto University, Kyoto, Japan, and Department of Chemistry, University of Oregon, Eugene, Oregon 94703. Received April 28, 1981. Revised Manuscript Received July 28, 1981

Abstract: The synthesis and spectroscopic properties of 12-fluororetinal and 12-fluororhodopsin are described. A comparison of these properties and the photobleaching sequence with the parent retinal and rhodopsin is made. A ¹⁹F NMR spectrum of the pigment is reported.

The use of fluorine labels to study structural properties of enzymes is a well-established technique. The label offers the obvious advantage of being able to employ the nondestructive nuclear magnetic resonance method without any interfering signals from the protein or the detergent. On the other hand the highly electronegative substituent could introduce other complications. In applying the method one must therefore examine with care that a fluorinated analogue still retains all characteristic properties of the molecule of concern.¹ Even with this possible complication, the method has been successfully applied to several systems, including the following: alkaline phosphatase,² α -chymotrypsin,³ and aspartate transaminase.⁴

Recently we reported the preparation and absorption properties of 10-fluoro- and 14-fluororhodopsin.⁵ Subsequently the preparation of a fluorinated aromatic rhodopsin analogue was also described.⁶ We now wish to report the successful preparation of 12-fluororetinal and 12-fluororhodopsin. The location of the fluorine label on the configurationally important 11,12-double bond makes the pigment analogue an interesting one. More importantly the results will show that the analogue has properties more akin to the visual pigment rhodopsin, thus making it an ideal substitute. Some preliminary ¹⁹F NMR data will also be presented.

Results

11-cis-12-Fluororetinal [(all-E)-12-Fluororetinal] (1). The synthetic route we used was essentially that described by Machleidt and co-workers in their syntheses of fluorinated vitamin A analogues.⁷ The fluorine atom at C₁₂ was introduced by the Horner reaction of β -ionylideneacetaldehyde with lithium triethylphosphonofluoroacetate to give (11E)- and (11Z)-tetraene ester 2 (11E/11Z \approx 3) in 84% yield. Separation of the isomers was readily effected by flash column chromatography. Subsequent elaboration of the carbon skeleton (2 \rightarrow 1) proceeded with complete retention of the 11E geometry, thereby obviating the necessity

Scheme I

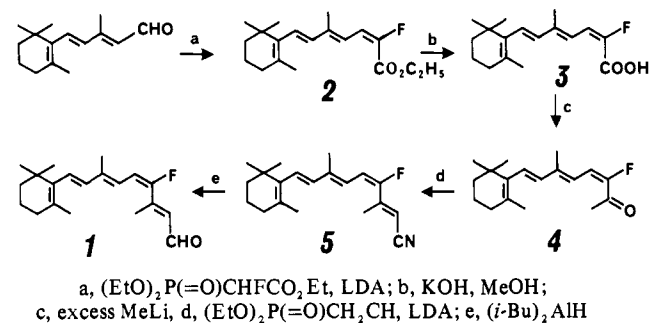

of photochemically introducing this critical *cis* linkage. All spectroscopic properties of the intermediates agreed with their assignments and are listed in the Experimental Section. The configuration of the 12-fluororetinal isomers was clearly established by the magnitude of the three bond H,F coupling constants ($J_{H,F}^3(\text{cis}) \approx 20\text{--}25$ Hz and $J_{H,F}^3(\text{trans}) \approx 30\text{--}40$ Hz)⁸ and the proton chemical shifts. The NMR data of 1 along with that for the corresponding all-trans (11Z), 9-cis (9Z,11Z) and 13-cis (11Z,13Z) isomers which were obtained in a separate synthetic sequence⁹ are listed in Table I.

* Address correspondence in the following manner: R.S.H.L., H.M., A. E.A., and M.D., University of Hawaii. Y.S. and T.Y., Kyoto University. F.W.D., University of Oregon.

[†]R.S.H.L. wishes to dedicate this paper to George S. Hammond on the occasion of his 60th birthday.

(1) For a leading reference on ¹⁹F NMR on proteins see: Sykes, B. D.; Hull, W. E. *Methods Enzymol.* **1978**, *49*, 270-95.

(2) Hull, W. E.; Sykes, B. D. *Biochemistry* **1976**, *15*, 1535-46.

(3) Gerig, J. T.; Halley, B. A.; Ortiz, C. E. *J. Am. Chem. Soc.* **1977**, *99*, 6219-25.

(4) Critz, W. J.; Martinez-Carrion, M. *Biochemistry* **1977**, *16*, 1554-8, 1559-64.

(5) Asato, A. E.; Matsumoto, H.; Denny, M.; Liu, R. S. H. *J. Am. Chem. Soc.* **1978**, *100*, 5957-60.

(6) Matsumoto, H.; Asato, A. E.; Denny, M.; Baretz, B.; Yen, Y.-P.; Tong, D.; Liu, R. S. H. *Biochemistry* **1980**, *19*, 4589-94.

(7) Machleidt, H.; Wessendorf, R. *Justus Liebigs Ann. Chem.* **1964**, *674*, 1-10; **679**, 20-25; **1965**, *681*, 21-29.

(8) Emsley, J. W.; Phillips, L.; Wray, V. *Prog. Nucl. Magn. Reson. Spectrosc.* **1977**, *10*, 85-756.